

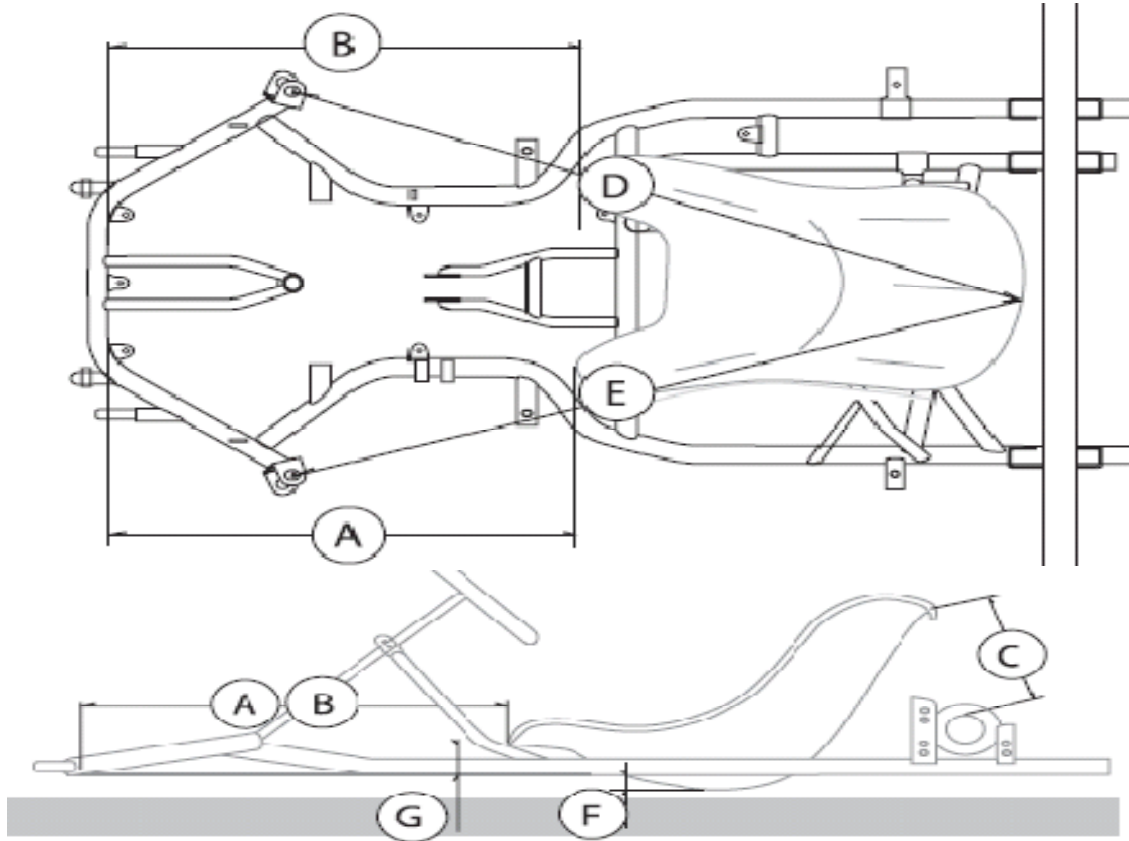

## 2009 Kosmic Seat Setup (Mercury + Lynx)



Dimensional Measurements

### Driver Height

	A	B	C
5' - 5'2"	590mm	595mm	230mm
5'3" - 5'7"	600mm	605mm	220mm
5'8" - 5'10"	625mm	630mm	210mm
5'11" +	635mm	640mm	205mm



1. When installing the seat it is important to insure that the main welded seat stays are fitted to the seat without any bind. Therefore, depending on the seat size you may have to take a dead-blow hammer and bend the seat stays so they are parallel and approximately 2mm from the seat. The 2mm distance will insure the correct measurement for the J3/CIK Seat washer to be installed.
2. When mounting the seat to the lower welded tabs on the chassis make sure to install the proper amount of steel washers between the seat and tab. J3 Competition recommends using 'steel' instead of rubber or composite materials
3. Drilling Mounting Holes - It is crucial to make sure the holes drilled in the seat line up with the fixed mounting hole on the chassis. Any misalignment will cause the seat to not function properly. Don't worry if you have to oblong the holes in the seat to get the correct fit, it is more important to have an accurate alignment